

Overview

NAGSIM.2D is a finite element software program for the computer simulation of two dimensional metal forming processes. It can simulate large plastic deformation of the part as well as elastic deformation of the tools. It compliments NAGFORM for obtaining alternative forming sequences to form a part. NAGFORM uses design logic, forming rules and simple analyses to come up with possible forming progressions. Using NAGSIM.2D, the user can verify and improve any sequence design through FEA simulation.

Eliminate Trial & Error in Forming

NAGSIM.2D allows the user to simulate the part forming in a computer before running it in the machine. NAGSIM.2D provides quick information to:

- Reduce die trials and costly mistakes.
- Improve tool life.
- Predict and eliminate defects.
- Reduce scrap.
- Predict mechanical properties of formed part.
- Determine influence of lubricants.
- Determine effects of heat treatment of blank on tool life.
- Shorten print-to-part time and improve part quality.

A Complete and Easy-to-Use Solution

NAGSIM.2D provides a complete and easy-to-use solution from creating a model of the forming operation to post-processing of simulation results. NAGSIM.2D's graphical user interface is tailored specifically for simulating metal forming operations. NAGSIM.2D has its own CAD module to create geometry of the workpiece and the tools. The part geometry can also be imported in DXF format from other CAD systems such as AutoCad, SolidEdge etc. The geometry can also be stored in Part Library for reuse.

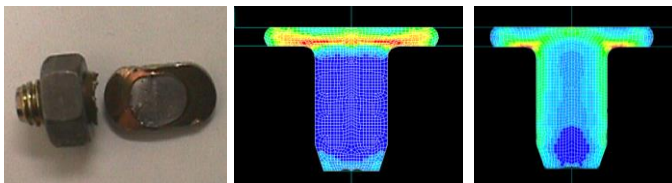

Reduced Strains with Redesigned Process

Efficient and Robust Solver

NAGSIM.2D uses an incremental finite element analysis solver that is specifically suited to metal forming operations with large plastic deformation. Two types of problems can be analyzed:

- Plane Strain - deformation of long parts.
- Axisymmetric - deformation of round parts.

Material Database

NAGSIM.2D has a database of materials commonly used in cold forming. New materials can be easily created and stored in the database. The flow properties of the material are defined dependent upon strain and strain rate.

Automated Meshing and Remeshing

NAGSIM.2D incorporates an automatic element mesher. The starting geometry of the part and the tools are meshed automatically. After the deformation process starts, the program automatically remeshes the part if the old mesh gets excessively distorted or if it is desired to mesh certain areas with finer mesh than the other.

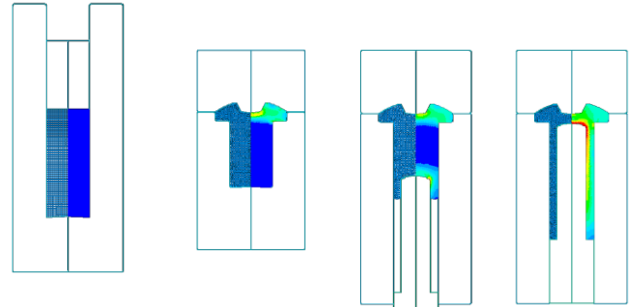

Simulation of Forming Sequence of a Rivet

Cold, Warm and Hot Forging

NAGSIM.2D does not include any thermal analysis. However, its formulation includes dependence of flow stress of the material on strain and strain rate. NAGSIM.2D can be applied to cold forming at ambient temperatures where material's flow stress is primarily strain dependent. For applications like warm or hot forging, where temperature changes cannot be neglected, NAGSIM_Gen.2D can be used. NAGSIM_Gen.2D is a special version of NAGSIM.2D program that includes thermal analysis during metal deformation.

Special Features

- Simple and Does not require extensive FEA background.
- Simulate multiple operations easily using templates.
- DXF interface to CAD systems.
- Stand-alone program.
- Integral 'Mini' CAD system.

Other Features

- **Interference Fit / Shrink Fit Calculator** - This calculator estimates the displacement and associated stresses in the insert and casing. It also includes:
 - A visual representation of stresses (Tangential, Radial and Difference) in the Insert and Casing.
 - Forming Pressure Input on the inside of the Insert. User can study the combined effect of interference fit and the inside forming pressure on the stresses inside the insert and the casing.

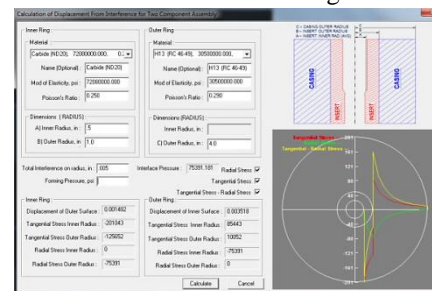

- **Mini Cad System –** NAGSIM.2D program includes a user friendly mini 'CAD' system. Using this, the user can create the part and tool drawings or modify the imported drawings within NAGSIM.

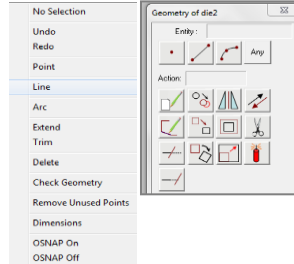

- **Progression Drawings –** Based on the simulation of the deforming part in various stations, NAGSIM.2D can create a progression drawing. The results can be exported to a DXF CAD file for comparison with designed progression.

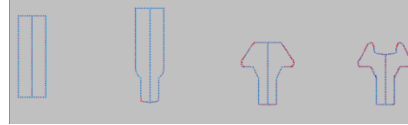

Results

NAGSIM.2D provides a complete insight into the forming process. The results include: Material flow, stress distribution, strain distribution, formation of laps, non filling of die cavity, load displacement, tool stresses, and contact between the part and the tools. Animation of results presents a clear visual of the forming operation.

- **Part Strain & Tensile Damage-** A part can fracture due to high Strains or Tensile Stresses. Based on the FEA simulation, the program determines the Strain levels and the Damage factors that can be used to predict part failure.

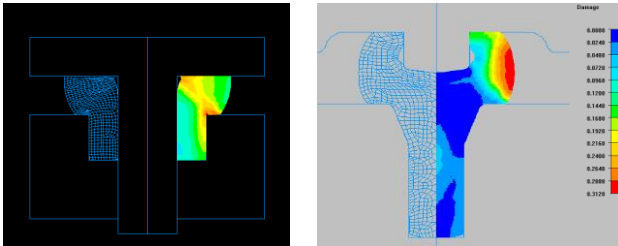

- **Load Stroke Curve –** The program can predict the load required to deform the part in a particular station and compare it against the machine capacity.

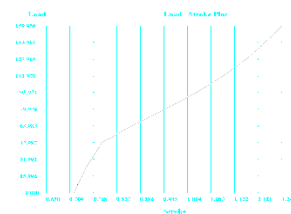

- **Tool Loads –** The program displays the contact points between the deforming part and the tools at each step. The graphics display shows the force vectors exerted by the deforming part on the tools at the contact nodes.

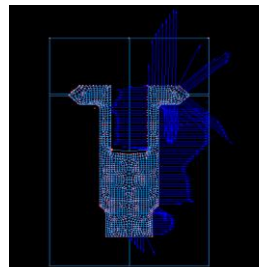

- **Grain Flow /Flow Lines Prediction –** Flow lines defines the path of material movement during the deforming process.

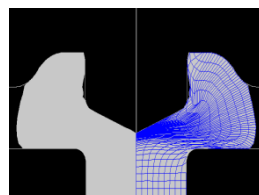

- **Lap Prediction –** The program has the capability to predict any folds / laps in the part through forming.

- **Elastic Stress –** Using NAGSIM, the user can predict the principle stresses in the tool. The fatigue life of a tool is directly proportional to the numeric values of the stresses in a tool during a forming cycle.

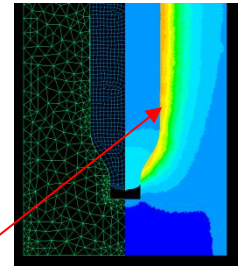

Stresses In The Tools

- **Press-Fit / Shrink-Fit –** The program calculates and displays the stresses on the tools based on the shrink fit applied to it. The analysis allows the user to determine the necessary shrink fit amount for a forging operation.

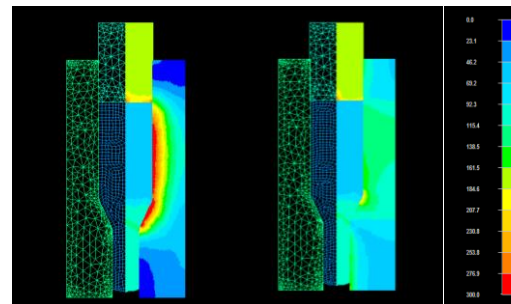

Effective Stress Without Shrink Fit

Effective Stress With Shrink Fit

- **Elastic Tool Deflection**
The program provides a magnified view of the deflection in the tools during the forming operation.

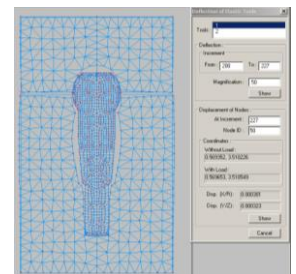

- **Animation of Velocity Vectors at Grid Points-** Velocity vectors show the instantaneous direction of the metal flow at the grid points. It is useful in studying the grain distortion.

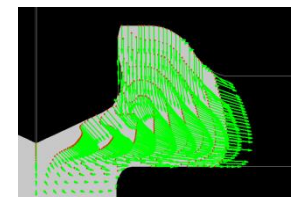

- **Tracing a Point in Forging Sequence –** The user has the capability to trace a point on the part (cut-off or final part) throughout the simulation.

